

## CCIE-LAB

**Note 1:** There are two sections, Section A and Section B. There is some overlap between the Sections.

**Note 2:** Section A contains 9 labs. Section B contains 8 Labs. Total number of labs is 17.

### Section A – older 9 Labs

#### Lab 1.

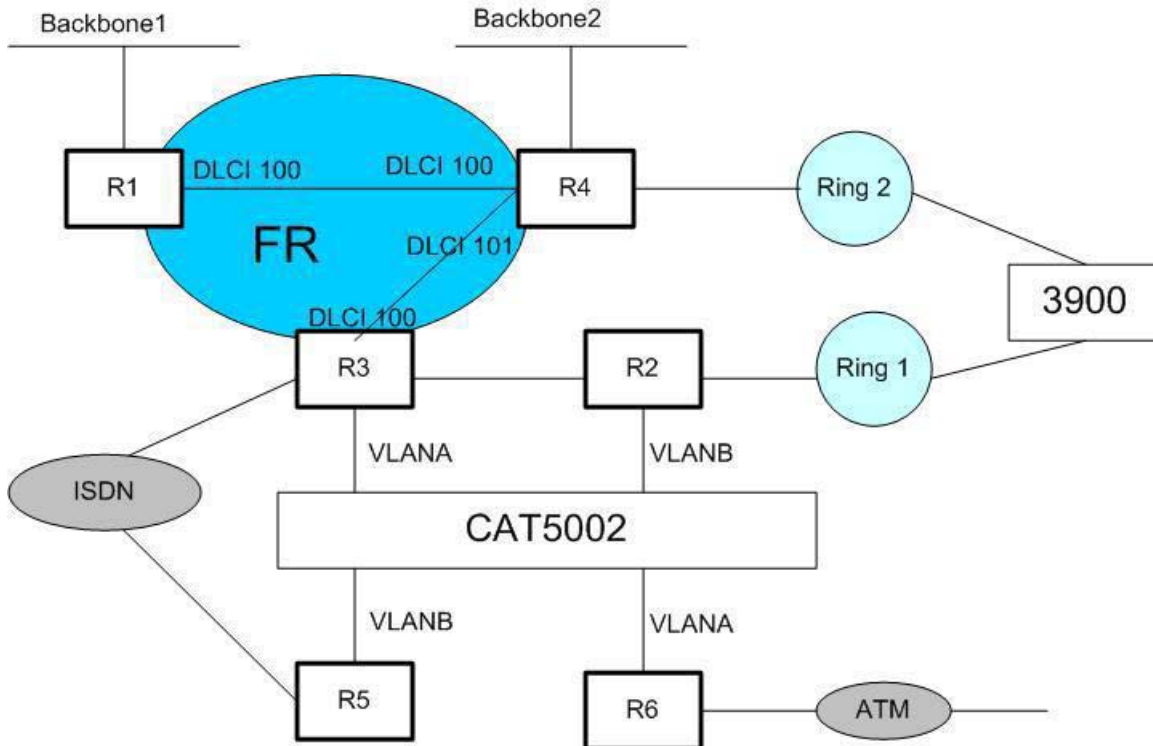

#### Day 1, Forenoon:

##### 1. Commserver (1 point)

Configure reverse telnet. line1-6 are R1-R6, line7 is CAT5002, line8 is 3900, line9 is backbone switch.

**Answer: No exec, transport input all**

1. **2. Physical connection (1 point)**
2. **3. Draw a topology diagram (1 point)**
3. **4. Loopback address (1 point)**

Include ip address, area number, VLAN, etc. makes it updated.

Setup loopback address as 132.Y.X.X at your router, where Y is your rack number and X is your router number.

**5. CAT5002 setup (1 point)**

R3 in VLAN A, use 100, R5 in VLAN B, use 200. Set sc0 (132.3.9.9) in VLAN A, And make the switch able to reach all the topology through R3.

**6. Address (2 points)**

All the interfaces use 132.Y.0.0 network as their addresses and use 24bits mask. The frame relay interface use 27 bits mask. Draw them on your diagram Answer: Imply that the loopback address use 24bits mask, don't use 32 bits mask.

**7. Frame-relay setup (2 points)**

Setup frame relay-relay, the frame relay switch is a 45000 which also ac as a backbone router. The switch is configured as fully meshed, but you are demanded to only use the pvc showed on the diagram they provide. (see the diagram)

**8 RIP setting (2 points)**

R1 ethernet address is 150.100.1.Y. setup RIP in R1, several network will send to R1 from Backbone 1, you are requested to permit only 193.68.3.0 to add in your RIP routing table and advertise it and 150.100.1.0 to your topology. Also advertise only the classful network 132.3.0.0 to your RIP domain.

**Answer: Distribute-list, mutual redistribute**

**9.OSPF**

**9.1 Basic configuration (2 points)**

Frame-relay interface in area 0; R4's tokenring interface in area 4; serial interfaces between R3 and R2, R2's tokenring interface, VLAN A in area 3; VLAN B in area 5; make area 5 as NSSA area. Put all loopback interface in the area. Make all interfaces reach each other.

**Answer: virtual-link, nssa**

**9.2 default-information (2 points)**

Make R2 generate a default route to area 5, make the default route only appear on R5.

**Answer: At R2: Area 5 nssa default-information originate**

**9.3 external route (2 points)**

Make another loopback interface in R5 (network 192.192.1.0) . male this network able to be reached by ospf topology but you are not